



Policy No.: _____

Insured: _____

Agent: _____

Location of Risk: _____

**WOOD/COAL BURNING FACILITY
QUESTIONNAIRE**

REQUIREMENTS

1. A photo of the wood/coal burning facility must be submitted with this Questionnaire.
2. Questionnaire and photo must be submitted with application for insurance.
3. Questionnaire must be inspected and signed by a licensed contractor or member of local fire department when facility is NOT factory installed or commercially installed by appliance distributor or licensed expert.

STOVE INFORMATION

TYPE Radiant Circulating Franklin Other (specify): _____

MAKE/NAME By: _____ U.L. Approved?..... Yes No

USE Primary Heat Auxiliary Heat Cooking Other (specify): _____

INSTALLED By: _____ Date: _____

FLOOR PROTECTION Asbestos Millboard Covered with Metal Metal Stone/Brick Other (specify below) _____

WALL PROTECTION Asbestos Millboard Covered with Metal Metal Asb. Millbrd Other (specify below) _____

**CHIMNEY
&
STOVE PIPES**

CHIMNEY TYPE: Factory Masonry Other (describe): _____

How often checked for creosote build-up? _____

Date Last Cleaned: _____ By Whom? _____

Does vent pass through a combustible partition?..... Yes No

If yes, is protection thimble or sleeve used?..... Yes No

Does pipe vent pass directly through the roof? Yes No

Are any other heating units vented to chimney?..... Yes No
(describe below) _____

Is stove vent system equipped with heat reclaiming unit or flue radiator? Yes No

CLEARANCES

1. Side of unit to nearest wall inches.
2. Rear of unit to wall inches.
3. Top of stovepipe to ceiling inches.
4. Bottom of unit to floor inches.
5. Front of unit to front edge of floor protection inches.
6. Size of stovepipe used inches.
7. Size of thimble or roof joist shield inches.

Do these distances comply with the manufacturer's standards?..... Yes No

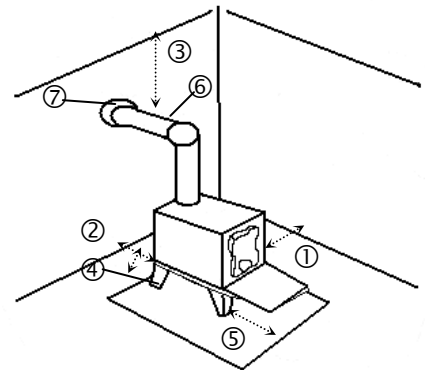

MISCELLANEOUS

FUEL Wood Coal Other (specify): _____

PREVENTION Fire Extinguisher in Room?..... Yes No Smoke Alarm? Yes No

ADDITIONAL REMARKS _____

Inspector Signature: _____

Date Inspected: _____

PHOTO MUST BE ATTACHED